

**TERMINALE A SNODO RILUBRIFICABILE**  
**BALL-JOINT END WITH GREASE NIPPLE**  
**NACHSCHMIERBARER GELENKKOPF**

**CSTS..C**

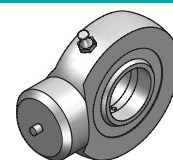
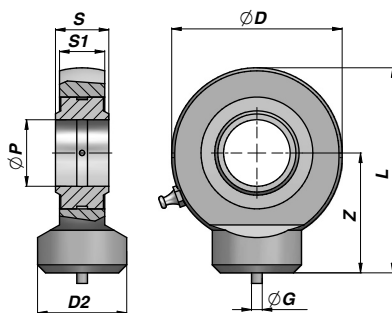

Codice Code Bestell-Nr.	ØP	Z	S	ØD	S1	L	ØD2	ØG	FC (kN)	kg
*CSTS010C00	10	24	9	29	7	38,5	15	3	8,15	0,04
*CSTS012C00	12	27	10	34	8	44	17,5	3	10,8	0,06
**CSTS015C00	15	31	12	40	10	51	21	4	17	0,12
CSTS016C00 (A)	16	35	14	46	11	58	24	4	19	0,17
**CSTS017C00	17	35	14	46	11	58	24	4	21,2	0,18
CSTS020C00	20	38	16	53	13	64,5	27,5	4	30	0,26
CSTS025C00	25	45	20	64	17	77	33,5	4	48	0,45
CSTS030C00	30	51	22	73	19	87,5	40	4	62	0,67
CSTS035C00	35	61	25	82	21	102	47	4	80	1,02
CSTS040C00	40	69	28	92	23	115	52	4	100	1,40
CSTS045C00	45	77	32	102	27	128	58	6	127	1,93
CSTS050C00	50	88	35	112	30	144	62	6	156	2,69
CSTS060C00	60	100	44	135	38	167,5	70	6	245	4,60
CSTS070C00	70	115	49	160	42	195	80	6	315	7,00
CSTS080C00	80	141	55	180	47	231	95	6	400	11,00

FC = CARICO DINAMICO AMMESSO - MAX DYNAMIC LOAD - MAX DYNAMISCHE LAST

\* NON RILUBRIFICABILE - WITHOUT GREASE NIPPLE - NICHT NACHSCHMIERBAR

\*\* RILUBRIFICABILE MEDIANTE FORO - LUBRICATING HOLE IN THE HEAD - DURCH BOHRUNG NACHSCHMIERBAR

(A) = FUORI NORMATIVA - WITHOUT STANDARD - AUßER NORM

MATERIALE - MATERIAL: ACCIAIO - STEEL - STAHL ISO 12240-4 SERIE E - TIPO S

**TERMINALE A SNODO RILUBRIFICABILE**  
**BALL-JOINT END WITH GREASE NIPPLE**  
**NACHSCHMIERBARER GELENKKOPF**

**CSTS..N**

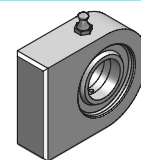
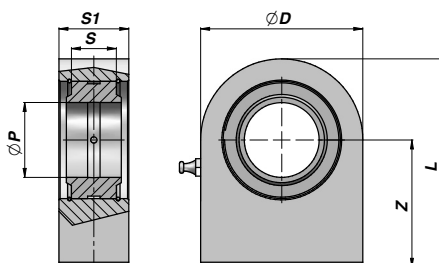

Codice Code Bestell-Nr.	ØP	Z	S	ØD	S1	L	FC (kN)	kg
CSTS015N00	15	31	12	45	16	53,5	17	0,22
**CSTS016N00	16	35	14	48	17,5	59	21,2	0,29
CSTS017N00	17	35	14	48	17,5	59	21,2	0,29
CSTS020N00	20	38	16	50	19	63	30	0,36
CSTS025N00	25	45	20	55	23	72,5	48	0,53
CSTS030N00	30	51	22	65	28	83,5	62	0,85
CSTS035N00	35	61	25	83	30	102,5	80	1,50
CSTS040N00	40	69	28	100	35	119	100	2,42
CSTS045N00	45	77	32	110	40	132	127	3,39
CSTS050N00	50	88	35	123	40	149,5	156	4,24
CSTS060N00	60	100	44	140	50	170	245	7,10
CSTS070N00	70	115	49	164	55	197	315	10,70
CSTS080N00	80	141	55	180	60	231	400	15,10
CSTS090N00 (1)	90	150	60	226	65	263	490	23,40
CSTS100N00 (1)	100	170	70	250	70	295	610	33,10
CSTS110N00 (1)	110	185	70	295	80	332,5	655	48,50
CSTS120N00 (1)	120	210	85	360	90	390	950	79,50

FC = CARICO DINAMICO AMMESSO - MAX DYNAMIC LOAD - MAX DYNAMISCHE LAST

\*\* RILUBRIFICABILE MEDIANTE FORO - LUBRICATING HOLE IN THE HEAD - DURCH BOHRUNG NACHSCHMIERBAR

(1) = PANTOGRAFATI - PROFILE PLATE - PANTOGRAPHIERT

MATERIALE - MATERIAL: ACCIAIO - STEEL - STAHL ISO 12240-1 SERIE E