

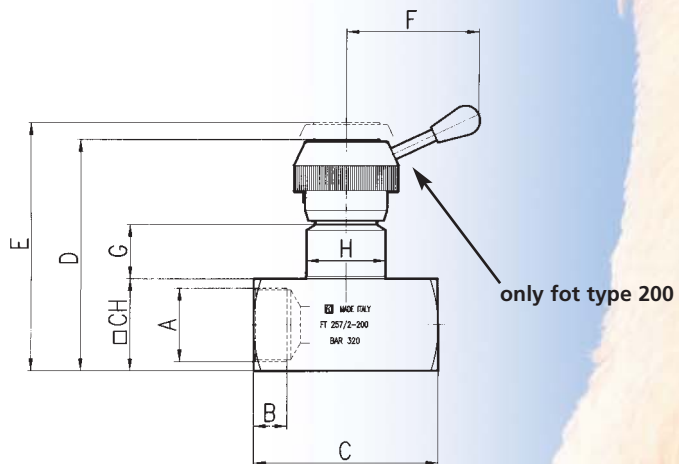
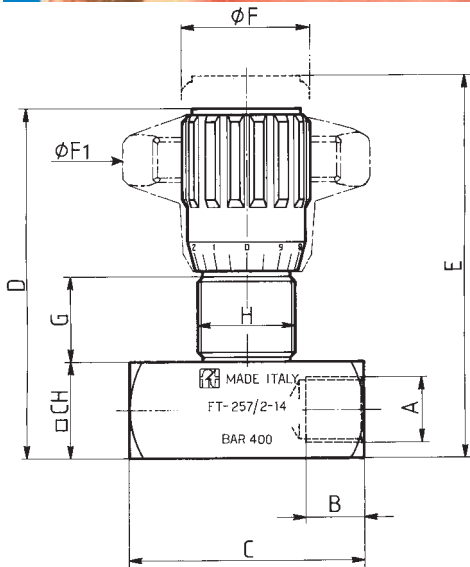

**MATERIALS**

BODY	9 S MN Pb 23 - UNI 5105
NEEDLE	1 C 40 - UNI 8373
OR	NITRILE
ANTIEXTRUSION RINGS	PTFE
KNOB	GD - AL SI 12 - UNI 5706
KNOB (MP)	ABS

**EXAMPLE FOR ORDERING**

	CODE	TYPE	PANNEL RING NUT	VITON SEAL	KNOB IN PLASTIC
STEEL	FT 257/2	18	G	V	MP
STAINLESS STEEL	FT 2257/2	38	G	-	MP

**DIMENSIONS**

TYPE	A UNI 338	B	C	D	E	Ø F	Ø F1	G	H	CH	WEIGHT KG
18	1/8" G	8,5	38	59	64	22	40	13,5	M17x1	16	0,110
14	1/4" G	12,5	49	71	78	27	50	17	M20x1	20	0,200
38	3/8" G	12,5	59	84	93	33	70	19,5	M25x1,5	25	0,375
12	1/2" G	15,5	68	97	107	38	80	21	M30x1,5	30	0,600
34	3/4" G	17	86	120,5	132,5	47	100	26,5	M40x1,5	40	1,250
100	1" G	20	105	151,5	167,5	58	120	35	M50x1,5	50	2,550
114	1 1/4" G	22	120	156,5	172,5	58	120	35	M50x1,5	55	3,000
112	1 1/2" G	24	134	167	181	58	120	35	M55x2	65	4,217
200	2" G	27	150	188	202	108	/	44	M65x2	75	7,300



## DOUBLE-ACTING SHUT-OFF

They allow flow control in both directions.  
They are equipped with a needle so to obtain:

- metallic seal;
- flow linearity at the opening;
- accurate control for a wide range of flow rate.

A double reference system made up of a decimal scale on the handle and of a keyed metal ring with graduated fractional scale and divided into sectors allows the identification of flow conditions.

A locking screw in the handle ensures stable flow values preventing accidental adjustments or movements due to vibrations.

A ring nut (G) is used to carry out the panel mounting, on request.

### On request

- Versions AISI 316 code FT 2257/2
- Viton seals (V)
- NPT Threads
- Equipped with ring nuts (G)
- Handlewheel in ABS (mp)

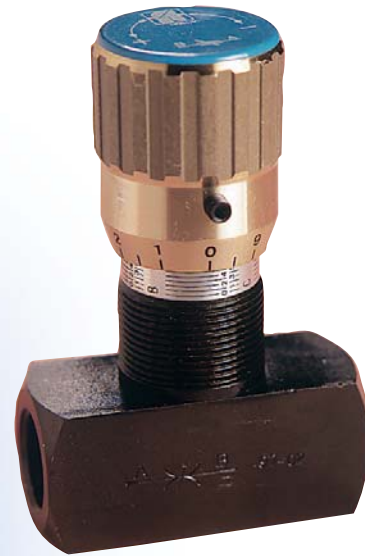

# FT 257/2

## TECHNICAL DATA

TYPE	FLOW SECTION CM <sup>2</sup>	WORKING PRESSURE BAR	MIN. BURSTING PRESSURE BAR	WORKING TEMPERATURE	FILTRATION GRADE μm
1 8	0,12	400	1600	-20°/+100°	25
1 4	0,19	400	1600	-20°/+100°	25
3 8	0,39	400	1600	-20°/+100°	25
1 2	0,68	400	1600	-20°/+100°	25
3 4	1,13	400	1600	-20°/+100°	25
1 0 0	2,09	320	1300	-20°/+100°	25
1 1 4	2,09	320	1300	-20°/+100°	25
1 1 2	3,14	320	1300	-20°/+100°	25
2 0 0	4,91	320	1300	-20°/+100°	25

FT 257/2-FT 258/2 - 18

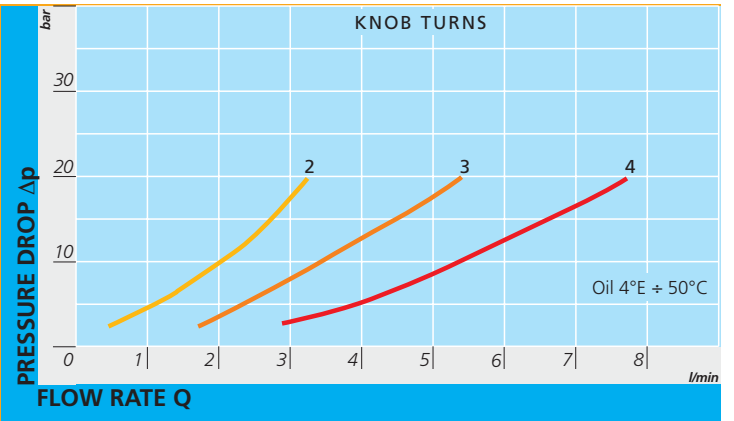

FT 257/2-FT 258/2 - 14

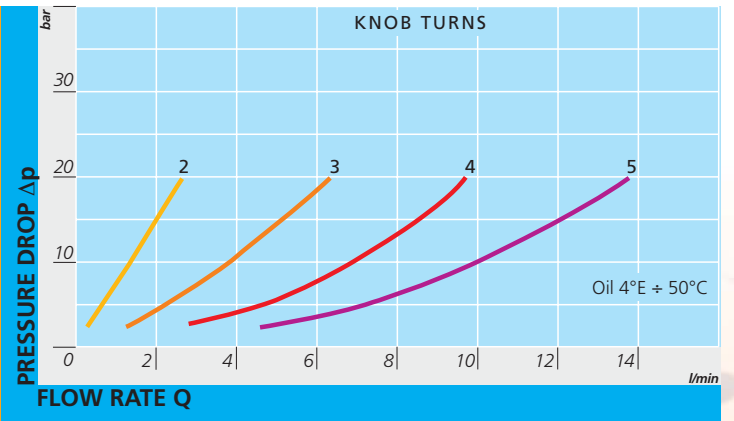

FT 257/2-FT 258/2 - 38

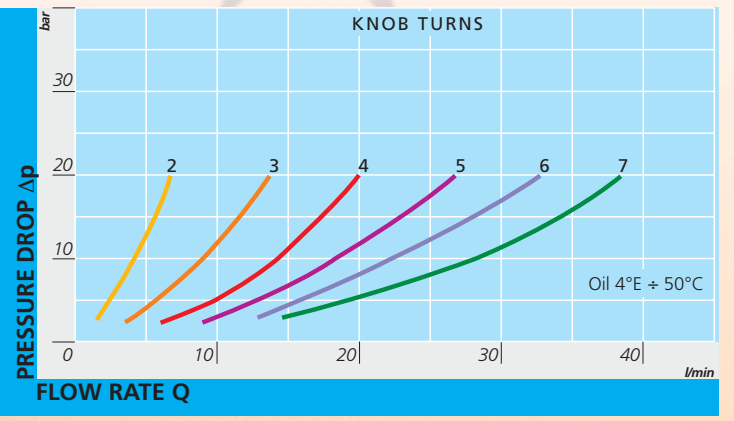

FT 257/2-FT 258/2 - 12

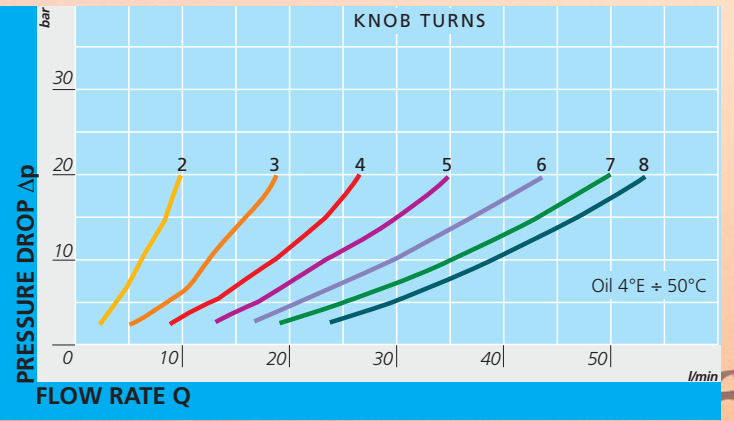

FT 257/2-FT 258/2 - 34

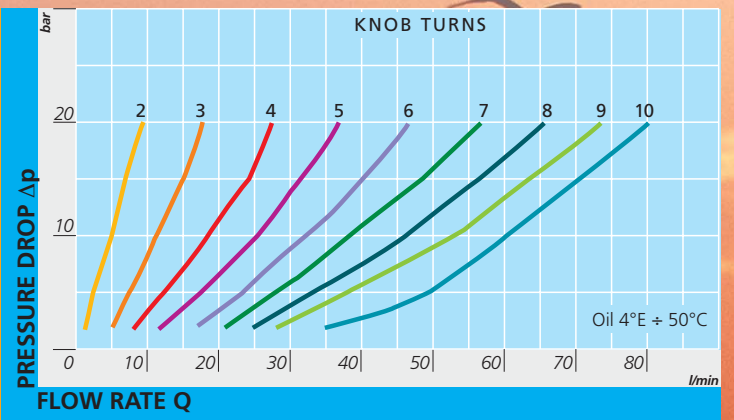

# FLOW RATE CURVES



FT 257/2 - FT 258/2

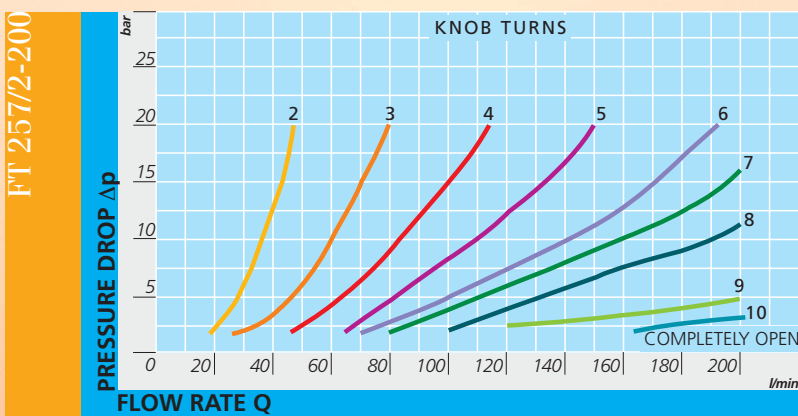
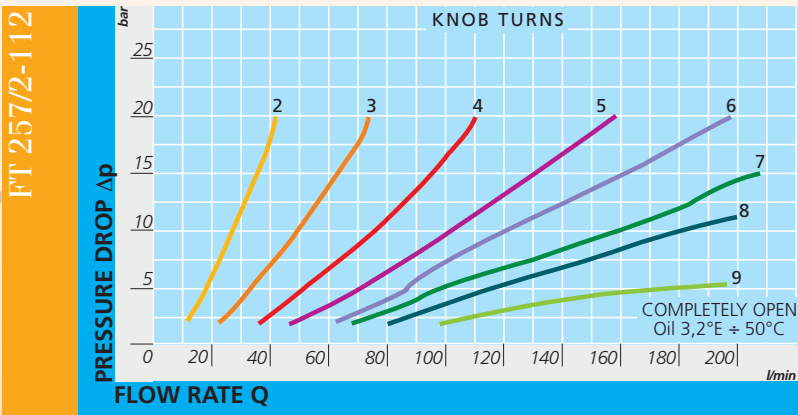
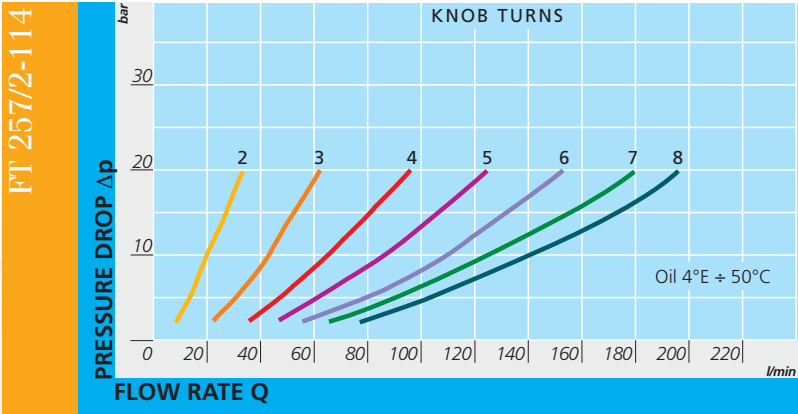
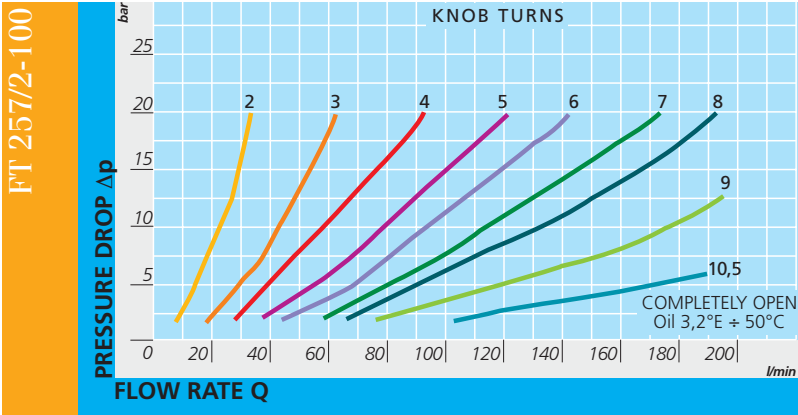



SERIE  
FT 257  
FT 258

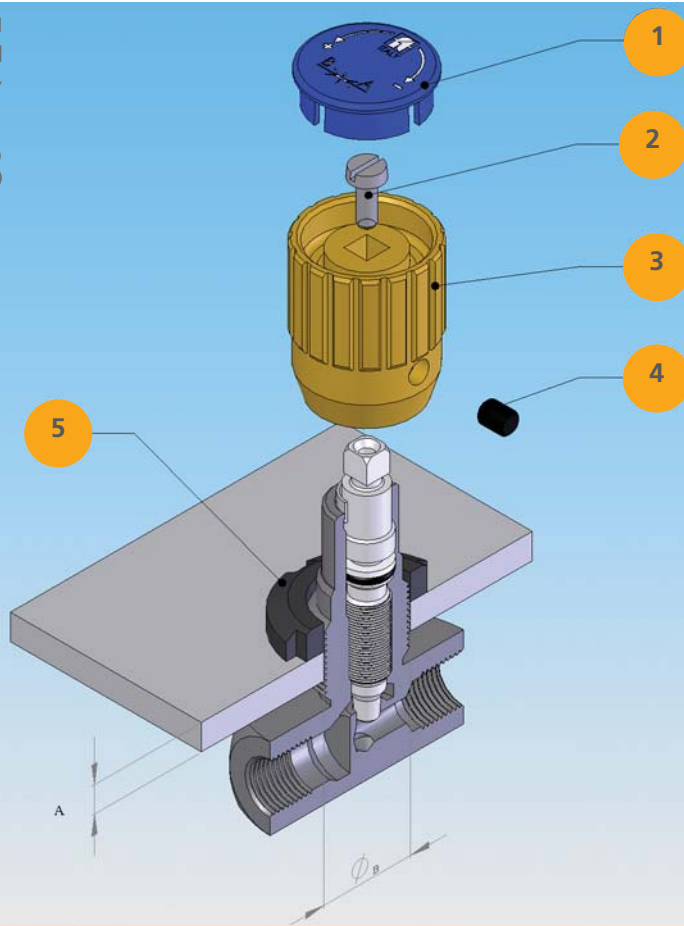

# PANEL MOUNTING INSTRUCTION

## PANEL MOUNTING

1°	UNSCREW LOCK SCREW (4)
2°	REMOVE COVER PLATE (1)
3°	UNSCREW SCREW (2)
4°	PULL OFF HANDLE (3)
5°	INSERT RING NUT (5), ON REQUEST IT IS SUPPLIED WITH THE VALVE

TYPE VALVE	PANEL THICKNESS A MAX	BORE FOR PANEL MOUNTING $\varnothing B$
18	6	18
14	8	21
38	10	26
12	10	31
34	10	41
100	10	51
114	10	51
112	12	56
200	12	66



SERIE FT 257 - FT 258